

Carefully to Carry

SEPTEMBER 2006

Lashing and securing deck cargoes

For the purposes of this article, the reader's attention is drawn to the requirements of the IMO *Cargo Securing Manual Regulations* and the IMO *Code of Safe Practice for Cargo Stowage and Securing*.

The IMO cargo securing manual

Regulations VI/5 and VII/6 of the 1974 SOLAS Convention require cargo units and cargo transport units to be loaded, stowed and secured throughout the voyage in accordance with the cargo securing manual (CSM) approved by the administration and drawn up to a standard at least equivalent to the guidelines developed by the International Maritime Organization (IMO).

The guidelines have been expanded to take into account the provisions of the *Code of Safe Practice for Cargo Stowage and Securing* (the CSS Code), the amendments to that Code, the *Code of Safe Practice for Ships Carrying Timber Deck Cargoes*, and the codes and guidelines for ro-ro vessels, grain cargoes, containers and container vessels, and ships carrying nuclear waste and similar radioactive products. Such individual publications are subject to amendments which need to be carried into the appropriate section of the cargo securing manual as they occur.

As from 1 January 1998, it is a mandatory regulation for all vessels, other than exempted vessels such as dedicated bulk solid, bulk liquid, and gas-carrying vessels, to have onboard an approved and up-to-date cargo securing manual. Some administrations may exempt certain cargo-carrying ships of less than 500 gross tons and certain very specialised ships, but such exemption should not be assumed in the absence of a formal exemption certificate.

It is a mandatory requirement for masters and ships' officers to be conversant with the CSS Code and the CSM Regulations, to understand their applications for the vessel in which they are serving, and to be capable of deploying correctly the hardware which goes with it. All securing of cargo units shall be completed before the ship leaves the berth. The CSM and its associated hardware are subject to port state control inspection. Violation of the CSM requirements may give rise to vessel detention and/or prosecution of the master and owners.



“The carrier shall properly and carefully load, handle, stow, carry, keep, care for and discharge the goods carried.”

Hague Rules,
Articles iii, Rule 2

Carefully to Carry Advisory Committee

This report was produced by the Carefully to Carry Committee – the UK P&I Club's advisory committee on cargo matters. The aim of the Carefully to Carry Committee is to reduce claims through contemporaneous advice to the Club's Members through the most efficient means available.

The committee was established in 1961 and has produced many articles on cargoes that cause claims and other cargo related issues such as hold washing, cargo securing, and ventilation.

The quality of advice given has established Carefully to Carry as a key source of guidance for shipowners and ships' officers. In addition, the articles have frequently been the source of expertise in negotiations over the settlement of claims and have also been relied on in court hearings.

In 2002 all articles were revised and published in book form as well as on disk. All articles are also available to Members on the Club website. Visit the Carefully to Carry section in the Loss Prevention area of the Club website www.ukpandi.com for more information, or contact the Loss Prevention Department.

The CSS Code and CSM Regulations and their amendments contain much sound and well-tryed advice, and should not be treated lightly. There are, however, a number of anomalies, and in some instances the applied text is difficult to reconcile with safe practice and sound seamanship. It is hoped that these shortcomings may be rectified by future amendments. In the meantime, the following suggestions may be found useful by ships' officers, loading superintendents, supercargoes, surveyors, and the like.

What is a deck cargo

The phrase 'deck cargoes' refers to items and/or commodities carried on the weather-deck and/or hatchcovers of a ship and thereon exposed to sun, wind, rain, snow, ice and sea, so that the packaging must be fully resistant to, or the commodities themselves not be denatured by such exposure. Even in ro-ro vessels, many areas above the actual 'hold' space can reasonably be considered as 'on deck' even though not fully exposed to the onslaught of wind and sea. The combined effects of wind, sea and swell can be disastrous. Where damage and loss occur to cargo shipped on deck at anyone's risk and expense, the shipowners, the master and his officers, and the charterers, must be in a position to demonstrate there was no negligence or lack of due diligence on their part.

Deck cargoes, because of their very location and the means by which they are secured, will be subjected to velocity and acceleration stresses greater, in most instances, than cargo stowed below decks. When two or more wave forms add up algebraically a high wave preceded by a deep trough may occur; this may be referred to as an 'episodic wave': a random large wave – noticeably of greater height than its precursors or successors – which occurs when one or more wave trains fall into phase with another so that a wave, or waves, of large amplitude is are produced giving rise to sudden steep and violent rolling and/or pitching of the ship. These are popularly – and incorrectly – referred to as 'freak' waves; they are not 'freak', however, because they can, and do, occur anywhere at any time in the open sea. The risk is widespread and prevalent. The stowage, lashing, and securing of cargoes therefore require special attention as to method and to detail if unnecessary risks are to be avoided.

Causes of losses

Unfortunately, despite all the loss-prevention literature available, there is a continuing incidence of the collapse and/or loss overboard of deck cargo items. Losses continue of large vehicles, rail cars, cased machinery, steel pipes, structural steelwork, packaged timber, freight containers, hazardous chemicals, boats, launches, etc. When investigated fully, the causes of

such losses fall into the following random categories which are neither exhaustive as to number nor mutually exclusive in occurrence:

- Severe adverse weather conditions.
- Lack of appreciation of the various forces involved.
- Ignorance of the relevant rules and guiding recommendations.
- Cost limitation pressures to the detriment of known safety requirements.
- Insufficient time and/or personnel to complete the necessary work before the vessel leaves port.
- Dunnage not utilised in an effective manner.
- Inadequate strength, balance and/or number of lashings.
- Wire attachment eyes and loops made up wrongly, including incorrect methods of using bulldog grips.
- Lack of strength continuity between the various securing components.
- Taking lashing materials around unprotected sharp edges.
- Incorrect/unbalanced stowage and inadequate weight distribution.
- The perversity of shore-based labour when required to do the job properly.
- Securing arrangements, both supplied and approved, not fully utilised on the voyage under consideration.

This last point is particularly true of ISO freight containers and timber cargoes carried on the weather-deck, and of large commercial vehicles carried in ro-ro vessels.

All interests involved in the lashing and securing of deck cargoes should bear in mind that high expense in the purchase of lashing materials is no substitute for a simple design and a few basic calculations before lashing operations commence. Other than in ro-ro and purpose-built container operations where standardisation of gear and rapid loading and turnaround times pose different problems, ship masters should be encouraged – on completion of lashing operations – to make notes of the materials used, to produce a representative sketch of the lashing system, to insist upon being provided with the test/proof certificates of all lashing components involved, and to take illustrative photographs of the entire operation. These, at least, will be of great assistance to the vessel's interest in the event of related future litigation.

General guidelines

The *Merchant Shipping (Load Lines) (Deck Cargo) Regulations 1968* (United Kingdom Statutory Instrument No. 1089 of 1968) set out some of the general ideas to be followed when securing deck cargoes. The list of requirements is not exhaustive but provides a realistic base from which to work, and reads, *inter alia*:

"2. Deck cargo shall be so distributed and stowed:

- 1) as to avoid excessive loading having regard to the strength of the deck and integral supporting structure of the ship;*
- 2) as to ensure that the ship will retain adequate stability at all stages of the voyage having regard in particular to:*
 - a) the vertical distribution of the deck cargo;*
 - b) wind moments which may normally be expected on the voyage;*
 - c) losses of weight in the ship, including in particular those due to the consumption of fuel and stores; and*
 - d) possible increases of weight of the ship or deck cargo, including in particular those due to the absorption of water and to icing;*
- 3) as not to impair the weathertight or watertight integrity of any part of the ship or its fittings or appliances, and as to ensure the proper protection of ventilators and air pipes;*
- 4) that its height above the deck or any other part of the ship on which it stands will not interfere with the navigation or working of the ship;*
- 5) that it will not interfere with or obstruct access to the ship's steering arrangements, including emergency steering arrangements;*
- 6) that it will not interfere with or obstruct safe and efficient access by the crew to or between their quarters and any machinery space or other part of the ship used in the working of the ship, and will not in particular obstruct any opening giving access to those positions or impede its being readily secured weathertight."*

Dunnage

If all deck cargo items could be structurally welded to the weather-deck using components of acceptable strength this would remove the necessity to consider coefficients of friction between the base of the cargo and the deck or dunnage on which it rests. Such is the large range of deck cargoes which do not lend themselves to such securing, however, that an appreciation of the sliding effect naturally raises the subject of coefficients of friction.

The values given for the coefficient of friction between dry timber and dry steel vary from 0.3 (17°) to 0.7 (35°), and between steel and steel sliding can occur at angles of inclination as small as 6°; but until some years ago there appeared to be no published data relating to the coefficient of friction between timber dunnage and the painted surface of steel decks or steel hatchcovers. Carefully controlled experiments were carried out in Liverpool under the author's supervision, using 9in x 3in x 8ft sawn pine deals, some of which had earlier been allowed to float in water; others had been stored in covered conditions so as to conform to normal atmospheric moisture content. The experiments were carried out on hinge-opening hydraulic-powered steel MacGregor hatchcovers in clean painted condition free of any unusual roughness and/or obstruction.

The tests used dry timber on dry covers; wet timber on dry covers; dry timber on wet covers; and, lastly, wet timber on wet covers. The lowest value – 0.51 (27°) – occurred with wet timbers on wet covers; the highest value occurred with wet timber on dry covers – 0.645 (33°).

On the basis of such results the lowest value of 0.51 (27°) should be accepted as relating to the most common condition likely to be found on the weather-deck of a sea-going ship, i.e., wet timber on wet decks. Hence, with inclination, only, and without any effects likely to be introduced by velocity and/or acceleration stresses due to rolling and pitching, timber dunnage alone will start to slide of its own accord at angles of inclination of 27°. Thereafter, sliding will continue at progressively smaller angles. It follows that, when the vessel is rolling and pitching and timber dunnage is unsecured, it will begin to slide at angles of inclination considerably less than 27°.

From such results it follows that the normal practice of utilising timber dunnage and of keeping downward-leading lashings as short and as tight as possible should be continued and encouraged. A near vertical lashing is of great benefit in resisting the cargo item's tendency to tip; a near horizontal lashing will greatly resist sliding forces. Do not overload lashing terminals and/or shackles. Think in terms of the 'effective strength' of a lashing – its 'holding power'. Balance the 'slip-load' of an eye in a wire with the strengths of a shackle, a bottle-screw and a chain. A lashing is no stronger than its weakest part.

Spread the load

Point-loading and uneven distribution of cargo weight can, and frequently does, cause unnecessary damage to decks and hatchcovers. Unless the weather-deck has been specially strengthened, it is unlikely to have a maximum permissible weight-loading of more than 3 tonnes/m². Similarly, unless hatchcovers have been

specially strengthened, it is unlikely they will have a maximum permissible weight-loading of more than 1.8 tonnes/m². The ship's capacity plan and/or general arrangement plan should always be consulted. If the information is not there, try the ship's stability booklet. In the event that specific values are not available onboard the ship, allow no more than 2.5 tonnes/m² for weather-deck areas; and no more than 0.75 tonnes/m² for hatchcovers in small vessels; 1.30 tonnes/m² in vessels over 100m in length. (The word *tonne* used later in this article means *tonnes force*.)

The adverse effects of point-loading are not always fully appreciated. On the one hand, a 6 tonne machine with a flat-bed area of 3m² will exert a down-load of 2 tonnes/m² (Fig 1a).

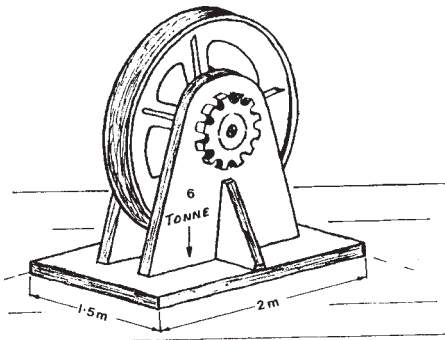

Fig 1a. The 6 tonne weight is exerting a down-loading of 2 tonnes/m²

On the other hand, a lady of 60kg weight in evening-shoes with heel areas 50mm² (0.00005m²) will exert a point-loading of 1200 tonnes/m² if, when dancing, she stands on your toe with all her weight on one heel (Fig 1b). Which is why our ladies are often more dangerous than machines!



Fig 1b. The heel of the lady's shoe is exerting a point-loading of 1200 tonnes/m².

When exceptionally heavy weights are to be carried, it may be necessary to shore-up the weather-deck from below; but, again, care must be taken to spread the load on the tween deck so as not to overload that plating. In the not so dense range of cargoes, units of 20 to 40 tonnes weight are common today, and stacking of unit weights is widespread. If a piece of machinery weighing, say, 30 tonnes with a base area of 6m² is placed direct on the weather-deck the point-loading will be 30/6 = 5 tonnes/m². If, however, the deck plating has a maximum permissible loading of 2.5 tonnes/m² then the minimum area over which that 30 tonne load must be spread is 30/2.5 = 12m².

Good dunnage must be used to spread the load, and it is always good practice to add 5% to the weight to be loaded before working out the dunnage area. For the 30 tonne weight, for instance, 31.5 tonnes would be used and the dunnage area would go from 12m² to 12.6m².

Dunnage timber is often no more than 6"x1" (150 x 25mm) rough planking; but where weighty cargo items are involved dunnage should not be less than 50mm (2") thickness x 150mm (6") width, and preferably 75mm (3") x 225mm (9"). It is acceptable, however, to use two dunnage planks nailed together securely to make up the thickness. A dunnage width greater than 150mm is always acceptable – 225mm (9") to 305mm (12"), for instance; but where the thickness goes to 75mm (3") care must be taken to choose straight-grained timbers of as great a width as possible, and to ensure that they are laid with the grain horizontal and parallel with the deck. There have been incidents in the past where what appeared to have been a soundly dunnaged and well-secured item of deck cargo broke adrift and was lost overboard due to a sequence of events commencing with the collapse of 3"x3" dunnage timbers along the curved grain used on its edge, followed by consequential slackness in otherwise adequate lashing arrangements, followed by increasingly accelerated cargo movement and finally breakage of the lashings.

Because of the random nature of grain configurations in the thicker dunnage timbers it is acceptable to achieve thicknesses by nailing planks together. A 2" thick dunnage timber can be made up using 1" thick planks, and a 3" thick dunnage timber can be made up using 2" and 1" thick timber planks, all securely nailed together. To a large degree, this will correct the tendency for separation in timber with a badly-aligned grain.

And remember, it will be as important to install good lower-level foot lashings as it will be to install downward-leading lashings if load-spreading dunnage is to remain fully effective.

Fig 2. The use of foot lashings with a twin-tier stack

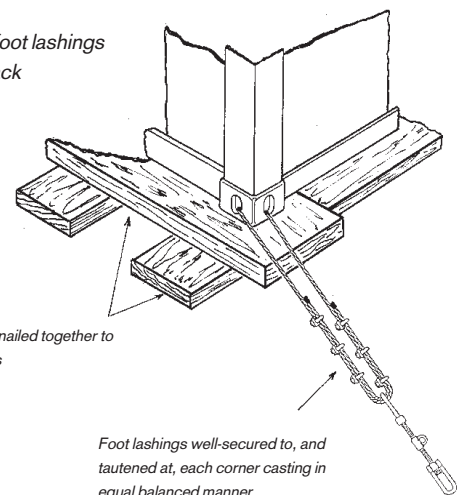

Good dunnage boards nailed together to support corner castings

Foot lashings well-secured to, and tautened at, each corner casting in equal balanced manner

Rolling periods

It is not the purpose of this article to deal with ship stability aspects, so far as those aspects may be avoided.

However, it is worth repeating a few established and relevant stability facts. For instance, the roll period of a ship is the time taken to make one complete transverse oscillation; that is, from the upright position to starboard inclination, from starboard inclination back to upright and through to port inclination, thence back to upright. Hence, if the roll period is 15 seconds and if the roll to starboard is 10° and the roll to port is 11° , the total 'sweep' within the 15 second roll period will be $10^\circ + 10^\circ + 11^\circ + 11^\circ = 42^\circ$.

When a ship rolls the axis about which the rolling takes place cannot generally be accurately determined, but it is accepted as being near to the longitudinal axis passing through the ship's centre of gravity. The time period of the roll is generally independent of the roll angle, provided that the roll angle is not large. Thus, a vessel with a 15 second roll period will take 15 seconds to make one full transverse oscillation when the roll angle (to port and to starboard) is anything from say 2° to 30° . The crux, from a cargo lashing viewpoint, lies in realising that a roll angle of 2° and a roll period of 15 seconds involves a 'sweep' of no more than 8° , whereas a roll angle of 20° and a roll period of 15 seconds involves a 'sweep' of 80° (ten times the arc) in the same time. The first will be barely noticeable; the second will be violent and will involve large transverse acceleration stresses particularly when returning to the upright.

Equally important is consideration of vertical acceleration as the ship pitches and scends. Calculation of this force is not so simple, but measured values give results varying from 0.5g amidships to 2g at the far forward end of the ship.

A 'stiff' ship is one with a large GM (metacentric height); difficult to incline and returns rapidly to the upright and beyond, sometimes with whiplash effect. This imposes excessive acceleration stresses on cargo lashings. A 'tender' ship is one with a small GM; easy to incline and returns slowly to the upright, sometimes even sluggishly. Although acceleration stresses are small the inclined angles may attain 30° , and the simple gravitational effects of such angles and slow returns may impose equally excessive stresses on cargo lashings. Try to avoid the extremes of either condition. And it is worthwhile working on the assumption that, if deck cargo is to remain safely in place during severe adverse weather conditions, the lashing arrangements should be sufficient to sustain 30° roll angles associated with 13 second roll periods, and 5° pitch angles associated with not less than 1g vertical acceleration.

Rule-of-thumb for lashing strength

The seaman's basic rule-of-thumb for securing cargoes with a tendency to move during a moderate weather voyage is simply that the sum of the minimum breaking-loads of all the lashings should be not less than twice the static weight of the item of cargo to be secured. That is, a single item of 10 tonnes weight requires the lashings used to have a total breaking-load of not less than 20 tonnes – on the positive assumption that the lashings are all positioned in a balanced, efficient, and non-abrasive manner. This rule may be adequate, or even too much, below decks – though not necessarily so in all instances – but it will not be adequate on the weather-deck in instances where calm seas and a fair weather passage cannot be guaranteed.

In circumstances where, for any time during a voyage, winds of Force 6 and upwards together with associated wave heights are more likely to be encountered, the increased stresses arising therefrom are those here considered, allowing for 30° roll angles with not less than 13 second roll periods. (And see Tables 3 and 4, herein, taken from the CSS Code and the CSM Regulations.)

In such cases, the sailor's rule-of-thumb – the '3-times rule' – tends to be that the sum of the safe working load of all the lashings shall equal the static weight of the cargo item to be secured; the safe working load being arrived at by dividing by 3 the minimum breaking-load/slip-load/holding power of the lashings. In other words, if the breaking-load/slip-load/holding power of all the lashings is 30 tonnes, then they can safely hold an item whose static weight is 10 tonnes – again on the assumption that all securing arrangements are deployed in a balanced, efficient, and non-abrasive manner. The author is not aware of any failures of lashings/securing arrangements or loss of deck cargo where this '3-times' rule-of-thumb has been applied in a sensible manner.

It is not arbitrary, however, because it is derived from the International Load Line Rules within which framework the United Kingdom Department of Transport, in earlier Instructions to surveyors, gave the following guidance, *inter alia*:

"When severe weather conditions (i.e. sea state conditions equal to or worse than those associated with Beaufort Scale 6) are likely to be experienced in service the following principles should be observed in the design of the deck cargo securing arrangements:

(iv) Lashings used to secure cargo or vehicles should have a breaking load of at least 3 times the design load, the design load being the total

weight of the cargo or cargo plus vehicle subjected to acceleration of:

0.7 'g' athwartships,

1.0 'g' vertically and

0.3 'g' longitudinally,

relative to the principal axis of the ship.

When sea state conditions worse than those associated with Beaufort Scale 6 are unlikely to be experienced in service, a lesser standard of securing such items of cargo might be acceptable to approval by the Chief Ship Surveyor.

The equipment and fittings used to secure the deck cargoes should be regularly maintained and inspected."

To condense those recommendations into a form simple to apply, reference should be made to the paragraph enclosed within the horizontal lines above. Put into practical and approximate terms, and using the phrase 'holding power' to indicate 'breaking-load/slip-load/holding power', this means:

- The total holding power, in tonnes, of all lashings holding the cargo item vertically downward to the deck should be equivalent to three times the ordinary static weight of the cargo item in tonnes: i.e. a 10 tonne cargo item requires total lashings having a holding-down potential of 30 tonnes.
- The holding power, in tonnes, of all lashings preventing the cargo item moving to port and to starboard should be equivalent to seven-tenths of the holding-down potential of item 1, above: i.e. a 10 tonne item requires lashings with holding power preventing transverse movement of 21 tonnes.
- The holding power, in tonnes, of all lashings preventing the cargo moving forward or aft should be equivalent to three-tenths of the holding-down potential of item 1, above: i.e. a 10 tonne item requires lashings with holding power preventing longitudinal movement of 9 tonnes.

The IMO 1994/1995 amendments to the CSS Code (now carried forward into the requirements for the preparation of the CSM) changes the emphases of the foregoing paragraphs as discussed hereunder:

The CSM 'rule-of-thumb' varies as the MSL of the different lashing components, as listed in its (*Table 1*) – shown on the next page – giving rise to five different answers to the one problem. For the most part, vertical acceleration is replaced by a 1g transverse acceleration, and vertical and longitudinal accelerations are not quantified except, that is, in the instance of containers of radioactive wastes, and the like, when

accelerations shall be considered to be 1.5g longitudinally, 1.5g transversely, 1.0g vertically up, and 2.0g vertically down. To date, the IMO have not offered an explanation as to why a tonne of radioactive waste should be considered to 'weigh' twice as much as, say, a tonne of tetraethyl lead or some other equally noxious substance.

The rule-of-thumb method given in Section 6 of the current CSS Code amendments indicates that the MSL values of the securing devices on each side of a cargo unit (port as well as starboard) should equal the weight of the unit, and a proposed amendment to Table 1 in Section 4 of the Code now provides MSLs as follows:

Table 1. Determination of MSL from breaking strength

Material	MSL
Shackles, rings, deckeyes, turnbuckles of mild steel	50% of breaking strength
Fibre rope	33% of breaking strength
Wire rope (single use)	80% of breaking strength
Web lashing	50% of breaking strength (was 70%)
Wire rope (re-useable)	30% of breaking strength
Steel band (single use)	70% of breaking strength
Chains	50% of breaking strength

"For particular securing devices (e.g. fibre straps with tensioners or special equipment for securing containers), a permissible working load may be prescribed and marked by authority. This should be taken as the MSL. When the components of a lashing device are connected in series (for example, a wire to a shackle to a deckeye), the minimum MSL in the series shall apply to that device."

Say that a cargo unit of 18 tonnes mass is to be secured using only shackles, web lashings, chains and turnbuckles – all MSLs of 50% breaking strength (BS). The unit will require 18 tonnef MSL on each side, namely, 36 tonnef total MSL (72 tonnef BS for these items), representing a total lashing breaking strength to cargo mass ratio of 72/18 = 4.

Secure the same cargo unit with steel band, only. Total MSL required will still be 36 tonnef (72 tonnef BS) but the MSL of steel band is nominated as 70% of its breaking strength – so this gives a total lashing breaking strength of $(36 \times 100) / 70 = 51.42$ tonnef, representing a total lashing breaking strength to cargo mass ratio of $51.42 / 18 = 2.86$.

Do the calculation using wire rope, re-useable, and the answer is $(36 \times 100) / 30 = 120$ tonnef: ratio $120 / 18 = 6.67$. For wire rope, single use, the answer is $(36 \times 100) / 80 = 45$ tonnef: ratio $45 / 18 = 2.5$, and for fibre rope the ratio is 6. And these ratios (or multipliers) remain constant for equal cargo mass. (If you do the same calculations using, say, 27 tonnes and 264 tonnes cargo mass, you will finish up with the same 4, 2.86, 6.67, 2.5 and 6 ratios (or multipliers). If a component was assigned a 66.67% MSL the result would be a ratio of 3 – the *three-times rule* multiplier.

The CSS Code is here changing the seaman's commonly-held understanding of the term 'rule-of-thumb' – a single multiplier easy to use and general in application – by inserting the MSL percentages to produce a range of rule-of-thumb multipliers.

Just to labour the point. If the cargo mass to be secured was 18 tonnes, and we use the five results obtained by using Sections 4 and 6 of the Code, the total lashing breaking strength required in each instance would be: 72 tonnef, or 51.48 tonnef, or 120.06 tonnef or 45 tonnef or 108 tonnef – and that seems to be an enigma at odds with commonsense!

One way of partly rationalising this 'enigma' is to create an additional column on the right-hand side of the MSL Table 1, as follows:

Table 2. Determination of MSL from breaking strength, including rule-of-thumb multipliers

Material	MSL	ROT multiplier
Shackles, rings, deckeyes, turnbuckles of mild steel	50% of breaking strength	4.00
Fibre rope	33% of breaking strength	6.06
Wire rope (single use)	80% of breaking strength	2.50
Web lashing	50% of breaking strength (was 70%)	4.00
Wire rope (re-useable)	30% of breaking strength	6.67
Steel band (single use)	70% of breaking strength	2.86
Chains	50% of breaking strength	4.00
<i>(Compare with overall general component)</i>	<i>(60.67% of breaking strength)</i>	<i>(3.00)</i>

By looking at Table 2 – and in respect of any cargo mass – you can use the multipliers without going

through all the calculations required by the Sections 4 and 6 route and, more importantly, you will be able to see clearly the extent to which the MSL multipliers degrade or upgrade the generally accepted three-times rule.

In the instance of the 18 tonne cargo unit given above, the lashings total breaking strength would be 54 tonnef when the three-times rule is applied. Simply $18 \times 3 = 54$ tonnef total BS, that is:

Cargo mass x Rule number = Lashings total breaking strength

Correction factors

While the three-times rule rule-of-thumb may be considered adequate for the general conditions considered above, Section 7 of the CSS Code Amendments provides Tables 3 and 4 where GMs are large and roll periods are less than 13 seconds, and those Tables, reproduced below, provide a measured way of applying that extra strength.

Table 3. Correction factors for length and speed

Length (m)	50	60	70	80	90	100	120	140	160	180	200
Speed (kn)											
9	1.20	1.09	1.00	0.92	0.85	0.79	0.70	0.63	0.57	0.53	0.49
12	1.34	1.22	1.12	1.03	0.96	0.90	0.79	0.72	0.65	0.60	0.56
15	1.49	1.36	1.24	1.15	1.07	1.00	0.89	0.80	0.73	0.68	0.63
18	1.64	1.49	1.37	1.27	1.18	1.10	0.98	0.89	0.82	0.76	0.71
21	1.78	1.62	1.49	1.38	1.29	1.21	1.08	0.98	0.90	0.83	0.78
24	1.93	1.76	1.62	1.50	1.40	1.31	1.17	1.07	0.98	0.91	0.85

Table 4. Correction factors for B/GM < 13

B/GM	7	8	9	10	11	12	13 or above
on deck, high	1.56	1.40	1.27	1.19	1.11	1.05	1.00
on deck, low	1.42	1.30	1.21	1.14	1.09	1.04	1.00
'tween deck	1.26	1.19	1.14	1.09	1.06	1.03	1.00
lower hold	1.15	1.12	1.09	1.06	1.04	1.02	1.00

NOTE: The datum point in Table 3 is length of ship 100m, speed of ship 15 knots and, in Table 4, B/GM = 13.

A word of caution. Ships' officers may care to ignore in Table 3 any correction factor less than 1, as shown in bold italic lettering. For all those values less than 1 let the rule-of-thumb calculation stand on its own and only apply the Table 3 factors when the values are greater than 1. This way the safety of the three-times rule or any other rule-of-thumb you may care to use will not be compromised.

Section 5 of the current CSS Code Amendments says:

"5 Safety Factor

Within the assessment of a securing arrangement by a calculated balance of forces and moments, the calculated strength (CS) of securing devices should

be reduced against MSL, using a safety factor of 1.5, as follows:

$$CS = \frac{MSL}{1.5}$$

The reasons for this reduction are the possibility of uneven distribution of forces among the devices, strength reduction due to poor assembly and others. Notwithstanding the introduction of such safety factor, care should be taken to use securing elements of similar material and length in order to provide a uniform elastic behaviour within the arrangement."

Many people were puzzled by that expression $CS=MSL/1.5$ appearing where it did in the text, because the phrase calculated strength appeared to have no direct relationship to the Sections 1, 2, 3 and 4 preceding it, nor did it sit easily with any attempt to apply it to Section 6 which followed it. It can now be stated with some authority that Section 5 (other than the third paragraph thereof) and its $CS=MSL/1.5$ expression does not relate to, nor should any attempt ever be made to apply it to, Section 6 or any other rule-of-thumb, other than the admonition in the third paragraph relating to securing elements of similar material and length.

Section 5 and its $CS=MSL/1.5$ are wrongly placed in the text. They relate to the Advanced Calculation Method illustrated in Section 7. To make sense of Section 5 there is currently a proposed amendment to Annex 13 indicating that the expression should be re-sited under paragraph 7.2.1. In Section 7 calculated strength is used within a set calculation method, and it is in that sense and in that context that calculated strength (CS) should be applied. So, unless you are involved with a full advanced calculation method, just ignore $CS=MSL/1.5$; and note that the advanced calculation method itself, is also under review. Readers should be alert to the likely soon promulgation of formal amendments to these aspects; act accordingly and avoid using the advanced calculation method for the time being.

Breaking strengths

Within the CSS Code and the CSM Regulations the phrase *breaking strength* is not defined. Within the context of those two documents, however, the phrase *breaking strength* could reasonably be taken to mean *the point at which the component, material or element can no longer support or sustain the load*, pending some possible amendments by the IMO.

The CSS Code defines the values of maximum securing loads (MSL) of mild steel components for securing purposes as 50% of breaking strength (see Table 1). The 1997 amendments to the CSM require

such components *inter alia* to have 'identification marking', 'strength test result or ultimate tensile strength result' and 'maximum securing load* (MSL)', all to be supplied by the manufacturer/supplier with information as to individual uses, and/strengths/MSL values to be given in kN – kiloNewtons. (To convert kN to tonnes force (tonnef) – multiply by 0.1019761, or for a rough value, divide by 10).

* The CSS Code 1994/95 amendments say:

"Maximum securing load is to securing devices as safe working load is to lifting tackle."

and Appendix 1 of the 1997 amendments to the CSM says:

"Maximum securing load (MSL) is a term used to define the allowable load capacity for a device used to secure cargo to a ship. Safe working load (SWL) may be substituted for MSL for securing purposes, provided this is equal to or exceeds the strength defined by MSL."

This latter definition is included in the proposed amendment to Annex 13 of the CSS Code.

There are difficulties likely to result from this mix of terms which raise questions about the validity of the cargo securing manuals issued and/or approved to date by the various national administrations, and the other approved certifying organisations. If the components are not identifiable by at least their MSLs, they are not complying with the CSM Regulations. To overcome this problem it has been suggested in the relevant quarters that all aspects could be safely met by attaching, with suitable wire, small coloured metal tags stamped with the MSL of the component, much as is currently required for components approved for the securing of timber deck cargoes. Responses received from the industry to date would give positive support to this proposal.

The Committee's advice to ships' officers and others trying to apply the requirements of the CSM/CSS Code is this: if the chains, shackles, rings, and the like, available to you are not clearly identified as to their MSLs (and remember, they should be so identified) use the stamped SWL of a lifting shackle as required by the CSM/CSS Code, thereby using a component which may have a breaking strength two-times greater than is needed, but you will have complied with the letter of the Regulations. Alternatively, it is suggested that the best method may be to multiply the stamped SWL value by 4 to obtain the breaking strength, and apply the percentages given in Table 1 to obtain the MSL – and then remove that component from any possibility of use for lifting purposes by tagging it. This should then have fulfilled the spirit of the Regulation without resorting to the use of massively oversized lashing components.

Wire rope

It is recommended that for efficient lashing purposes wire ropes should be round-stranded, flexible and not so great in diameter as to make their use cumbersome. The most common of such general purpose wires is 16mm diameter (2" circumference) of 6x12 construction galvanised round strand with 7 fibre cores having a certificated minimum breaking load of 7.74 tonne (tonnes force). This is the cheapest wire for its size, will turn easily around thimbles and lashing points, can be spliced or bulldog gripped without difficulty and is easily handled.

Other wires of different construction and of varying sizes or strength may be needed for particular lashing purposes and the certificated minimum breaking load should always be verified before taking such wires into use.

Fig 3. Wire rope

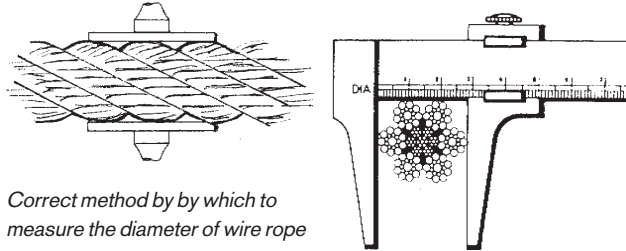

Correct method by which to measure the diameter of wire rope

Uncoiling. Correct method



Unreeling. Incorrect method

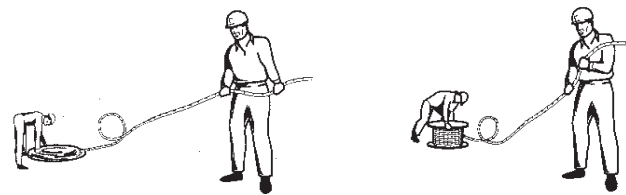

In some instances wires intended for use as lashings are supplied pre-cut to precise length and with eyes or attachment devices already formed in one or both ends. Such purpose-made items are usually sold with certificates stating the test load and minimum break load applicable. If test certificates are not supplied then they should be requested. More commonly the wire is supplied in coils and must be cut to length onboard ship with eyes and attachment devices formed and fitted as required. Where this is the case, eyes formed by bulldog grips must be made up in accordance with the manufacturer's instructions otherwise the eye terminations will tend to slip under loads very much smaller than the certificated breaking load of the wire.

Fig 4. Grips and clips

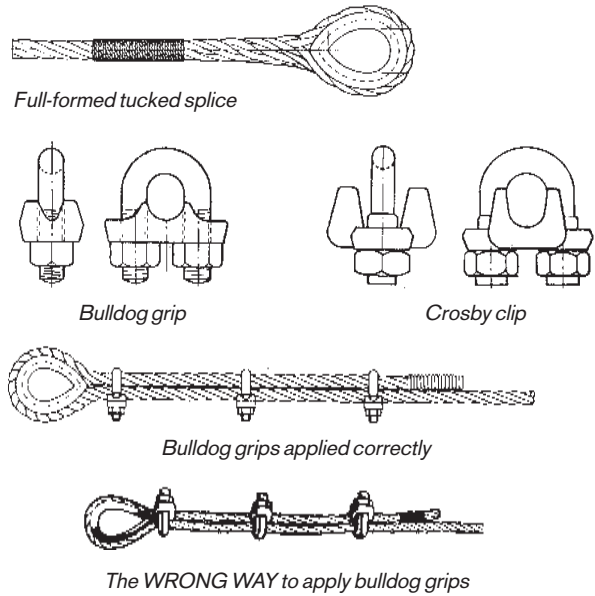

The application of bulldog grips

Experience continues to show that the most common cause of lashing failure is the incorrect application of bulldog grips. Tests indicate that where an eye is formed around a thimble in the correct manner the lashing arrangement will hold secure with loads up to or even in excess of 90% of the nominal break-load (NBL) of the wire before slipping or fracturing, although it is usual and recommended to allow not more than 80%. Without a thimble, the eye when made-up correctly, can be expected to slip at loads of about 70% of the NBL. Where the correct procedures are not followed slippage is likely to occur at much reduced loads. Under strictly controlled conditions, more than 100 tests were applied on a licensed test bed on 16mm and 18mm wire rope lashing configurations. The configurations tested were as illustrated in Fig 5 a, b and c.

As a result of such tests the following recommendations are made:

It should be stressed that these recommendations relate to cargo lashings only. Lifting gear and other statutory applications require a minimum of 4, 5 and 6 grips for 16mm diameter wire and upwards, respectively. It is also most important to ensure that the bulldog grips are of the correct size in order to correspond with the diameter of the lashing wire.

Recommended minimum number of bulldog grips for each eye – lashing purposes only:

Diameter of wire rope (mm)	Wire rope grips
Up to and including 19	3
Over 19, up to and including 32	4
Over 38, up to and including 44	6
Over 44, up to and including 56	7

An allowance of 150mm should be made between the last bulldog grip and the end of the 'dead' wire. It is important to ensure that the lashing wires are not cut short immediately next to the bulldog grips. The end of the 'dead' wire should be tightly taped.

Fig 5. Configurations tested

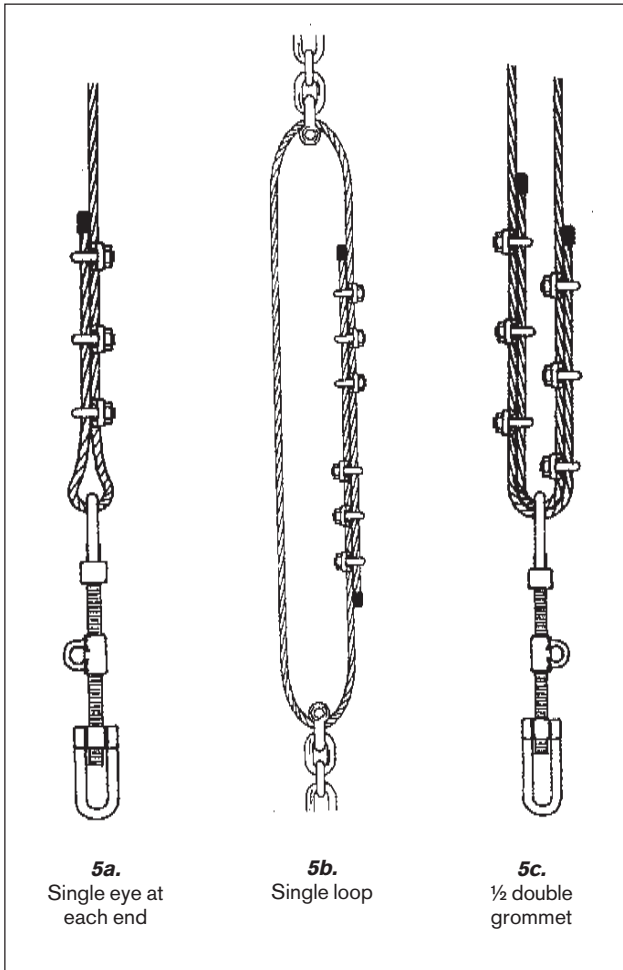

- Bulldog grips have a grooved surface in the bridge piece which is suitable for a standard wire of righthand lay having six strands. The grips should not be used with ropes of left-hand lay or of different construction. Crosby grips have a smooth surface in the bridge piece. The first grip should be applied close to the thimble or at the neck of the eye if a thimble is not used. Other grips should be placed at intervals of approximately six rope diameters apart (i.e., 96mm with a 16mm diameter wire; 108mm with an 18mm diameter wire).
- The grips must all face in the same direction and must be fitted with the saddle or bridge applied to the working or hauling part of the rope. The U-bolt must be applied to the tail or dead-end of the rope as illustrated in Fig 6a. If the grips are not applied as indicated, the effectiveness of the eye can be seriously affected.
- Ideally, all the nuts on the grips should be tightened using a torque wrench so that they may be set in

Fig 6. Correct application of Bulldog grips

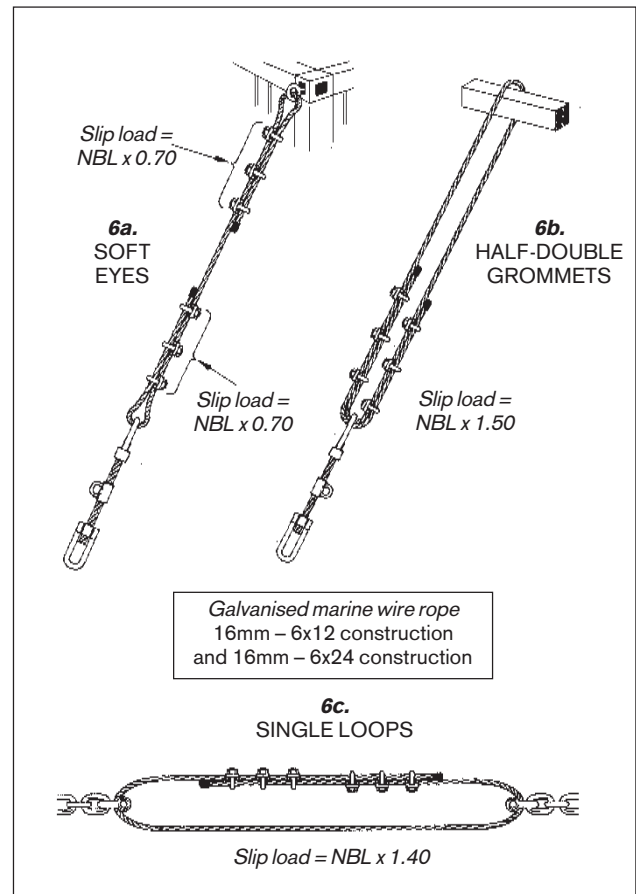

accordance with the manufacturers' instructions. In practice it may be sufficient to use a ring spanner although thereafter all the nuts should be checked periodically and adjusted as necessary.

Fig 7. Soft eyes – some other representative slip loads

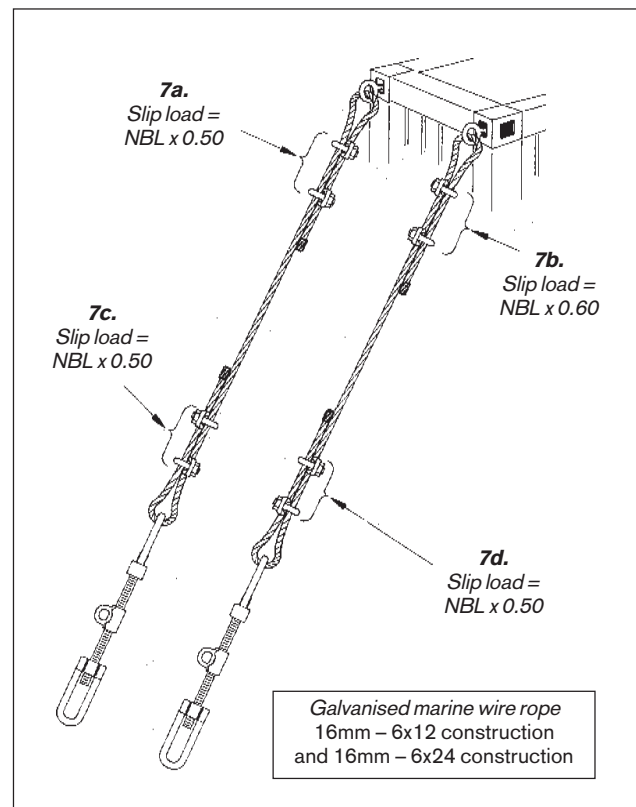

- Should a connection slip under load, it is likely that initially the rate of slip will be accelerated. The rate may then decrease, but until the load is removed the slip will not be completely arrested.
- As mentioned earlier, if three grips are applied in the correct manner and with an eye formed around a thimble (a hard eye) the eye will not fail or slip at loads of less than 80-90% of the NBL. Without a thimble the eye (a soft eye) made-up correctly can be expected to slip at loads in excess of about 70% of the NBL. See Fig 6a. This is referred to below as the 'slip-load' or 'holding power' of the eye.

Fig 8. Soft eyes – UNSAFE application of Bulldog clips

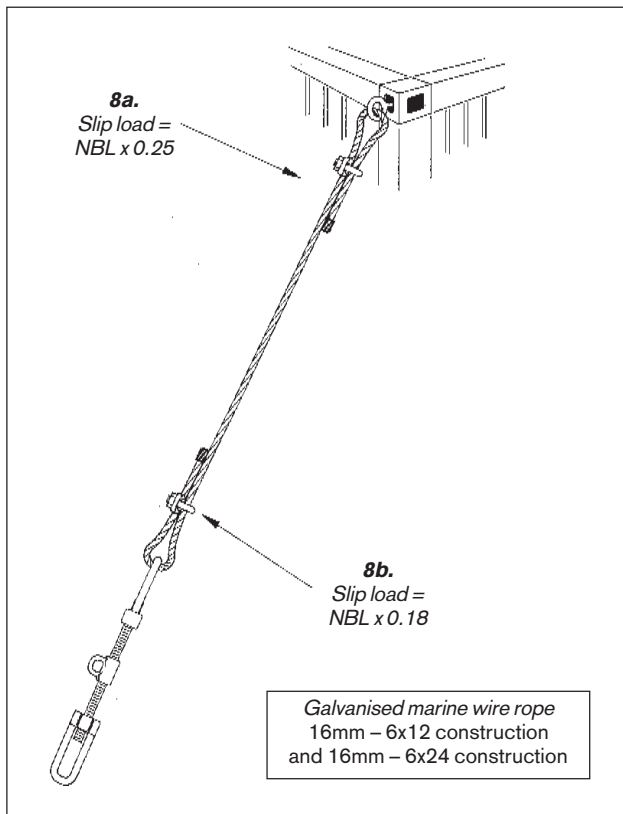

- The use of half-double grommets is widespread and it is sometimes wrongly assumed that the holding power will be twice the NBL of the wire. In fact, tests show that the slip-load will be only 1.5 times the NBL. See Fig 6b. The holding power also decreases as the number of grips is reduced. See Fig 9 and Fig 11b.
- The use of bulldog grips to join two ends of wire rope is to be avoided: again, it is sometimes wrongly assumed that this will provide a holding power of twice the NBL. In a single loop with six grips being used, (see Fig 6c) the slip-load will be about 1.4 times the NBL. The holding power decreases as the number of grips is reduced. (See Figs 10 and 11).
- In a soft eye, with 2 grips, and with one or both used in the reverse manner (see Fig 7 a, b and c) the eye

Fig 9. Half-double grommets – some other representative slip loads

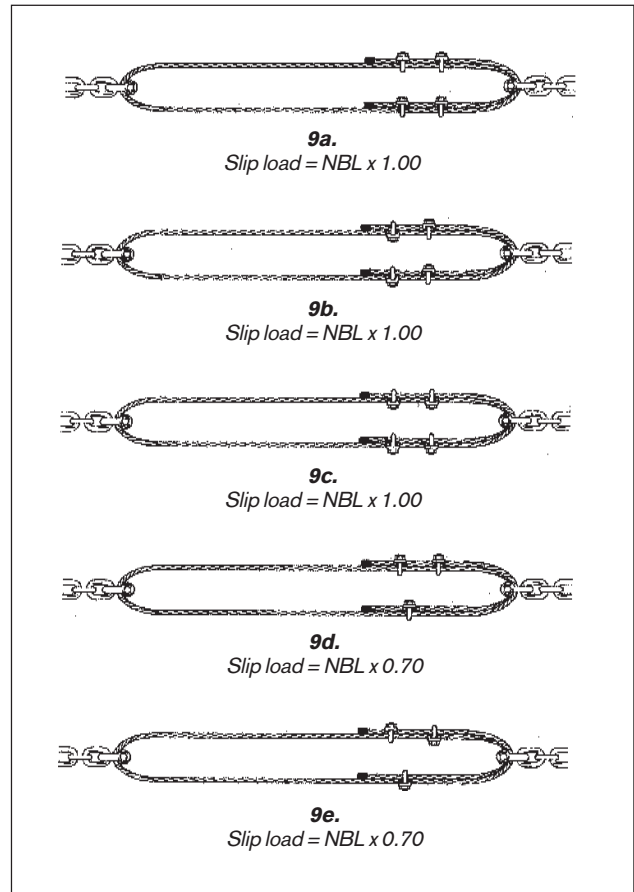
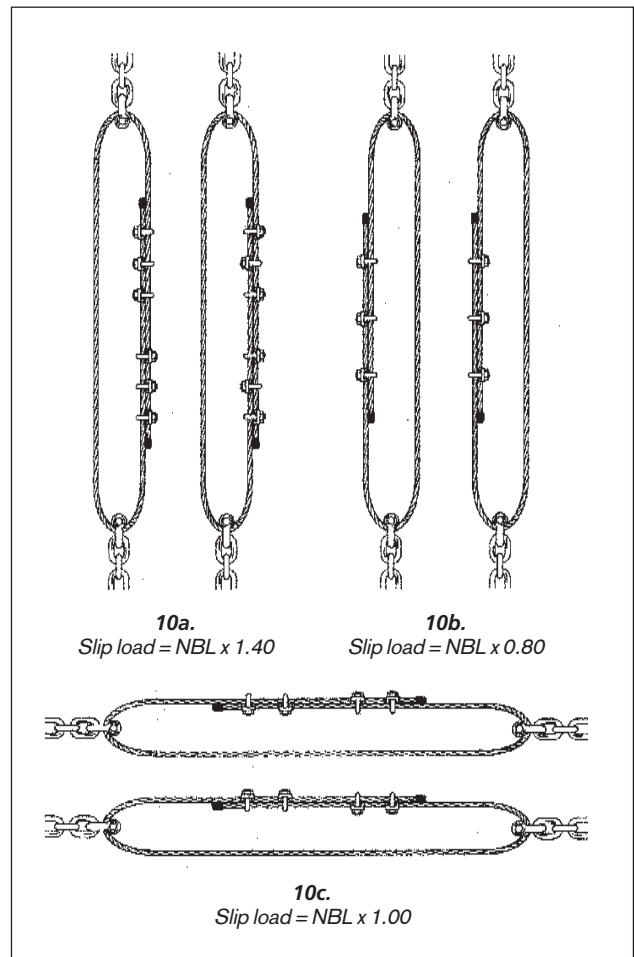

Fig 10. Single loops – some other representative slip loads



the eye can be expected to slip at loads of about 50% NBL. These configurations are the least efficient and, as indicated, the holding power is at most half the nominal break load of the wire.

- With a soft eye using only one grip the slip-load was found to be 0.25 NBL with the grip positioned correctly (Fig 8a) and 0.18 NBL with grip reversed (Fig 8b).

Fig 11. NOT recommended

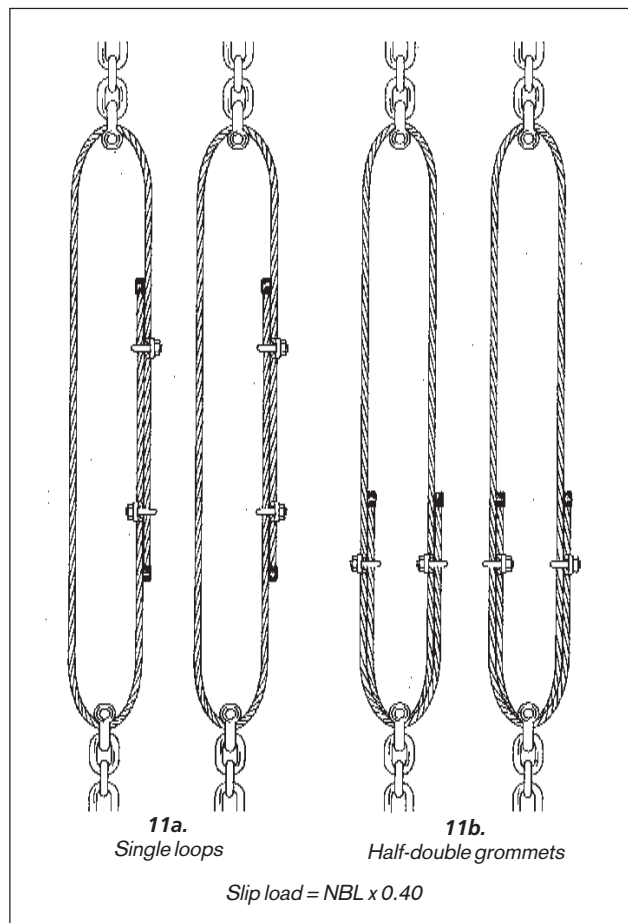

- A turnbuckle with a thread diameter of 24mm or more can be adjusted to set up a pre-tension of about 2 tonnes. If such a turnbuckle were attached to an eye made up in 16mm wire as shown in Fig 8 a and b, full tension in the wire would not be attained and the eye would slip at the grip under the pull of the turnbuckle, alone.

A word of caution before deciding to use half-double grommets (at NBL x 1.5) and single loops (at NBL x 1.4) as opposed to single eyes (at NBL x 0.7). At one terminal end in the instance of a half-double grommet, and at each terminal end in the instance of a single loop, there is no more material than at the terminal end of a soft eye.

If a properly made-up single loop breaks adrift, you have immediately lost twice the holding power allowable for a soft eye; if a properly made-up half-

double grommet breaks adrift, you have lost more than twice the holding power allowable for a soft eye; so it is most important to ensure that the terminal ends are connected by shackles or some other form of smooth, non-sharp-edged, component.

For instance: Instead of 25 single eyes, for convenience and time saving, you use 12 half-double grommets of 16mm 6 x 12 wire to secure a 46-tonne item of deck cargo. If one of the half-double grommets fractures at a poor terminal connection you lose 8.3% of the total holding power; if a soft eye had failed you would have lost only 4% of the total holding power. As remarked earlier, lashing and securing of deck cargoes is not an exact science: it's frequently a case of a balanced trade-off, but the trade-off should be based on information and a few quick calculations the basis for which this article hopefully provides.

Eyes and similar terminal ends in wire lashings should never be formed by the use of round turns and half hitches. Experience shows that initial slackness is seldom taken up sufficiently and that, even when it is, the turns and hitches tend to slip and create sharp nips leading to failure of the wire at loads well below those to be expected for eyes properly formed by the use of bulldog grips.

When attaching wires to lashing terminals on the ship's structure or the cargo itself every means should be taken to avoid hard edges, rough chaffing points, and sharp nips at the eye. Even where thimbles are not used the attachment of the eyes of the wire to lashing terminals may best be accomplished by using shackles of the appropriate size and break load.

Plastic coated wires

Plastic (PVC) coated galvanised standard marine wire of 18mm diameter and 6x24 construction is commonly used for various purposes where there is a need to avoid the risk of cutting or chafing. Such wire should be used with caution. Tests have revealed that if plastic covered wire is used in conjunction with grips, slippage is likely to occur at much reduced loads than would be the case for unprotected wire of the same size and characteristics. The plastic coating should be stripped from the wire where the bulldog grips are to be applied and from the surface of any wires coming into contact with each other.

Fire and explosion hazards

If lashing terminals are to be welded while or after loading cargo, great care should be exercised. Before undertaking any hot-work it is important to obtain a hot-work certificate from the local port authority. The authority should also be in possession of all relevant information relating to ship and cargo. The welders

themselves should be properly qualified and competent and, if welding is taking place either on deck or under decks, a proper fire watch should be mounted both at and below the welding site. Adequate fireproof sheeting should be spread below welding points. On deck, fire hoses should be rigged with full pressure on the fire line. A watchman should be posted for at least four hours after the completion of welding and a ship's officer should examine all spaces before they are finally battened down. Do not neglect these precautions. If in doubt, do not weld.

Positive action

When you see something being done badly or wrongly, stop the work and have it re-done correctly. When rigging foremen, stevedore superintendents and charterers' supercargoes insist on doing things wrongly and say they have always done it that way successfully, tell them they've just been lucky! Then make them do it correctly

One important aspect remains – ensure that the lashing points on the ship are sufficient in number and adequate in strength for the lashings they will hold.

Chain

The use of chain alone for the securing of general deck cargoes is not widespread. Where chain lashings are used they tend to be supplied in precise lengths already fitted with terminal points and tightening devices.

The advantage of using chain resides in the fact that under the normal load for which the chain is designed it will not stretch. Thus, if all chain lashings are set tight before the voyage and the cargo neither settles nor moves, nothing should cause the chain to lose its tautness. Hence it is widely used in the securing of freight containers, timber cargoes and vehicle trailers.

In general chain for non-specific uses is awkward to handle, tiresome to rig, difficult to cut to length, and does not render easily. For general purposes it is most effectively used in relatively short lengths in conjunction with or as a part of lashings otherwise composed of wire or webbing.

Webbing

The use of webbing slings and webbing lashings for cargo securing purposes has steadily increased over the past years. Operational results differ widely. There are instances where webbing is ideal for securing deck cargoes and there are other instances where it should be used with caution.

Special large bore pipes made of reinforced plastic or provided with contact sensitive outer coatings make

Fig 12. Webbing

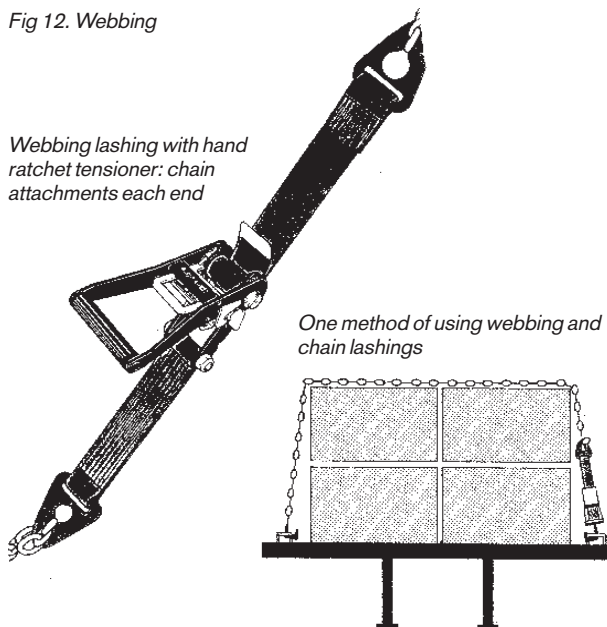

webbing an ideal securing medium because its relatively broad flat surfaces and reduced cutting nature allow it to be turned around and tightened against the pipes with short spans, producing a most acceptable stowage. On the other hand large, heavy, crated items or high standing heavy machinery where relatively long spans may be involved require wire or chain lashings, because sufficient unsupported tension is difficult to apply with webbing alone, although some of the 'superlash' systems now available can overcome this problem effectively.

Webbing in general is manufactured from impregnated woven polyester fibre and therefore will stretch more than wire rope. It is supplied in reels and may be easily cut and fashioned to any required length.

Webbing should not be used without clearly confirming from the manufacturer's literature its nature, breaking load and application. Recent independent tests confirm that good quality webbing will not fracture at loads less than those specified by the manufacturers. Tension on a hand ratchet can be obtained easily up to 0.54 tonnes and then with increasing difficulty up to a maximum of 0.60 tonnes. A spanner or bar must never be used to tighten a hand tension ratchet since recoil could seriously injure the user.

Webbing should be kept away from acid and alkalis and care taken to ensure that it is never used to secure drums or packages of corrosive materials or chemicals which, if leaking, might affect it. All webbing should be inspected frequently and if re-used care taken to ensure that all lengths are free of defects.

Protective sleeves should be used between webbing and abrasion points or areas. For securing ISO freight containers use only those webbing systems designed for such purpose.

Fibre rope

Ropes of up to 24mm in diameter are handy to use but are more likely to be found on cargoes that are stowed below decks. The use of fibre ropes for weather-deck cargoes should be restricted to light loads of limited volume in areas that are partly sheltered by the ship's structure. The reason for this is that where such ropes are used on deck difficulty is likely to be encountered in maintaining the tautness of the lashings when they are subjected to load stresses and the effects of wetting and drying out in exposed situations. The use of turnbuckles should be avoided: they may quite easily overload the rope lashing and create the very failure conditions, which they are designed to avoid. The tautening of rope lashings is best achieved by the use of bowsing ropes and frappings. At 24mm diameter, a sisal rope has a breaking strain of 7.5 tonnes, and a polyester rope 9 tonnes.

Composite rope, frequently referred to as 'lashing rope' is made up of wire fibres and sisal or polypropylene fibres which are interwoven thus adding to the flexibility of sisal and polypropylene some of the strength of steel. It is most frequently supplied in coils of 10mm diameter. The breaking strain of composite ropes should be considered as about 0.8 tonnes for sisal based and 1.8 tonnes for polypropylene based ropes.

Nylon fibre absorbs between 8% and 9% of water: the overall effect when under load is to reduce its effective strength by about 15%. Premature failure of nylon rope occurs under limited cyclic loading up to 70% of its effective strength. Therefore nylon rope is not recommended for deck cargo securing purposes.

The figures for breaking strain, which are quoted above, refer to new material and not to rope which has been in use for any length of time.

Shackles

Shackles are supplied in several shapes, sizes and strengths of material. The two shapes most commonly

Fig 13. Tightening rope lashings

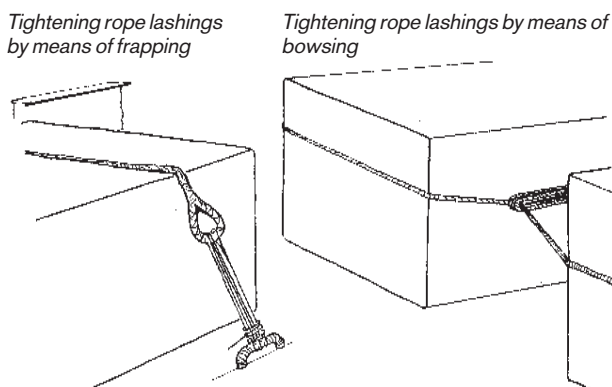

used for general cargo lashing purposes are the D-shackle and the Bow-shackle each with an eyed screw-pin. When using shackles it is correct to define their strength in terms of the safe working load although, as indicated earlier in this article at Table 1, *et al*, the CSS Code and the CSM Regulations define their maximum securing load (MSL) as 50% of the breaking strength; so when preparing combined cargo lashings always ensure that the MSL of the shackles selected is not less than the effective strength of the eyes or other configurations formed in the wire rope and similar materials.

Fig 14. Shackles and screws

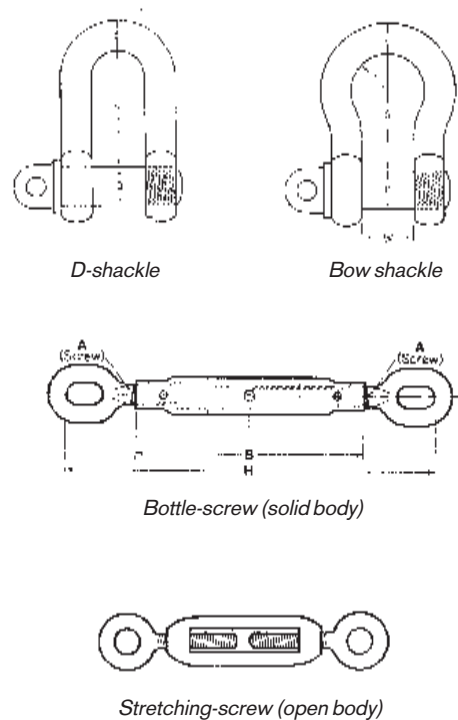

Turnbuckles

The same precautions apply to the use of turnbuckles. The word 'turnbuckle' is used collectively to include solid-cased bottle-screws and open-sided rigging screws or straining screws. These are most commonly used for general cargo lashing and are supplied in a range of sizes and strengths with a closed eye at each end. Open-sided rigging-screws and straining-screws tend to have noticeably lower strengths than solid bottle-screws of the same size. The suppliers or manufacturers should be asked to provide the relevant test data before those responsible for lashing cargoes assume a MSL or SWL which may be erroneous.

Solid bottle-screws are typically sold by size of screw-pin diameter. Those of 24mm diameter have a proof-load of 4 tonnes and those of 38mm have a proof-load of 10 tonnes. Special purpose turnbuckles are available with much greater strengths than those given above. These may have particular fittings and modifications such as those used in the container trade.

Again it is important that the manufacturers' literature should be consulted before such equipment is brought into use.

Turnbuckles should always be used with the pulling forces acting in one straight line. They should never be allowed to become the fulcrum of angled forces no matter how slight. Care should always be taken to see that the screws are at adequate extension when the cargo is finally secured. In this way scope is provided for further tightening if this should prove necessary during the voyage as the cargo and lashing arrangements settle. Where high torque upon a main lashing is involved the eyes of the turnbuckle should be seized or stopped against its own body in order to prevent the screws working back under load during the voyage.